

HOT TAP DIGITAL FLOWMETER (Including Rev. 3.0) INSTALLATION & MAINTENANCE

Model	Schedule 40 Pipe Size	Calibrated Range
H9095	2 NPT Schedule 40 Pipe	6-600 SCFM (10-1020 m3/hr)
H9096	2-1/2 NPT Schedule 40 Pipe	8-800 SCFM (13-1360 m3/hr)
H9097	3 NPT Schedule 40 Pipe	12-1200 SCFM (12-2000 m3/hr)
H9098	4 NPT Schedule 40 Pipe	20-2000 SCFM (34-3398 m3/hr)
H90100	6 NPT Schedule 40 Pipe	50-5000 SCFM (85-8495 m3/hr)
H90101	8 NPT Schedule 40 Pipe	60-6000 SCFM (102-10194 m3/hr)

Any of the following suffixes may be added to a model number to alter the flowmeter as listed. Please check with an application engineer if you have any questions.

-DAT	Includes Data Logger - See Lit 9021 for operation of Data Logger
------	--

Accuracy
Operating Pressure
Power
Wetted Materials
Ring Material
Display
Compliance

Specifications
Calibrated Range: 5% of reading, plus 1% of full scale for air temperatures between 20° and 120°F (-7° - 49°C).
Extended Range: For flows up to 50% more than maximum calibrated range, accuracy is 7% of reading for air temperatures between 40° and 120°F (4° - 49°C).
130 PSIG max
250mA at 24VDC
Stainless steel, gold, thermal epoxy Teflon, Aluminum and Viton (seal)
Aluminum
Four-digit LED display
CE and RoHS

Note: For use with compressed air and nitrogen only.

Application

The Hot Tap Digital Flowmeter may be used with either compressed air or nitrogen, at pressures from atmospheric to 130 PSIG. The air or nitrogen must be free of oil and suspended water droplets. Refer to the “Flowmeter Accuracy” above for the calibrated range of the particular meter. The meter will continue to read at much higher flow rates, but there may be significant inaccuracy.

Safety Precautions

Installation of the meter requires two hands, and missteps could cause a release of air that would startle the installer. Opening the valve at the wrong moment or withdrawing the drill without closing the corresponding valve would cause air containing sharp chips to blow out at high velocity.

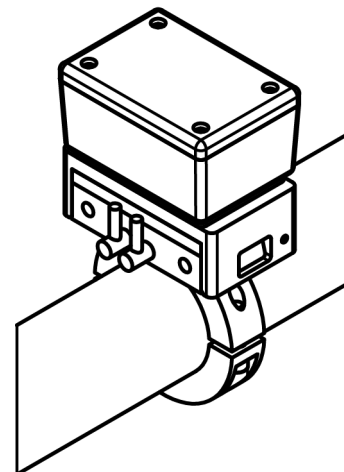

- Work should be done from a lift or staging, and fall protection must be provided where appropriate.
- Gloves and face protection must be worn.
- The installer should practice opening and closing the valves and withdrawing the drill several times before drilling the holes.

Normally, the chips formed by the drilling operation are small. If long chips are formed, the installer should back out the drill frequently to clear the chips so that they will not prevent the valve from being closed.

Location

The Hot Tap Digital Flowmeter may not be installed in a hazardous location. For installation in areas exposed to moisture, please contact an Application Engineer. Rev 3.0 meters meet NEMA 4 requirements. For best accuracy, the Hot Tap Digital Flowmeter should be installed with at least 30 diameters of straight pipe upstream and five diameters downstream. (Example: 30 diameters for a 1" Schedule 40 pipe = 30 X 1" = 30" of straight pipe.)

Avoid installing the Hot Tap Digital Flowmeter downstream of any item that could distort or concentrate the flow, such as a partially-closed valve, a regulator, a filter or moisture separator, two closely-spaced elbows in different planes, a long-radius elbow, an increase in pipe size or a curved hose. For these situations, allow at least 50 diameters of straight pipe between any such item and the meter. Select a location that meets these requirements and also provides good visibility from the plant floor.

Preparing for Installation

When the holes are drilled, metal shavings will enter the pipe. Make sure that filters or other provisions are present downstream to prevent the shavings from damaging downstream equipment, tools or products as well as considering any place where they could be blown out and cause an injury.

Prepare the meter for the pipe orientation and direction of flow. To switch the Hot Tap Digital Flowmeter between horizontal and vertical orientation, loosen the screws on the underside of the top bracket, rotate the display, the re-tighten the screws. Be careful not to loosen the screws more than necessary, and then tighten them securely. The flow arrow on the meter must be oriented to match the direction of flow in the pipe. If doing so will cause the display to be upside down, remove the cover of the meter, lift out the display, rotate both 180° and re-install.

Apply the "Holes in Pipe" decal so that it will be hidden when the meter is in place, but will be revealed when it is removed.

Installing the Meter

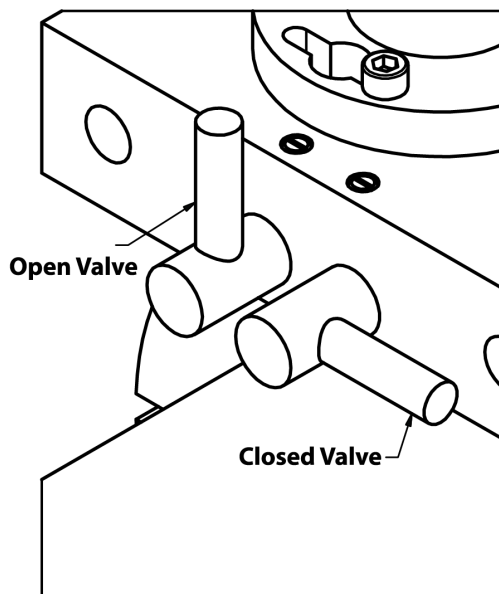
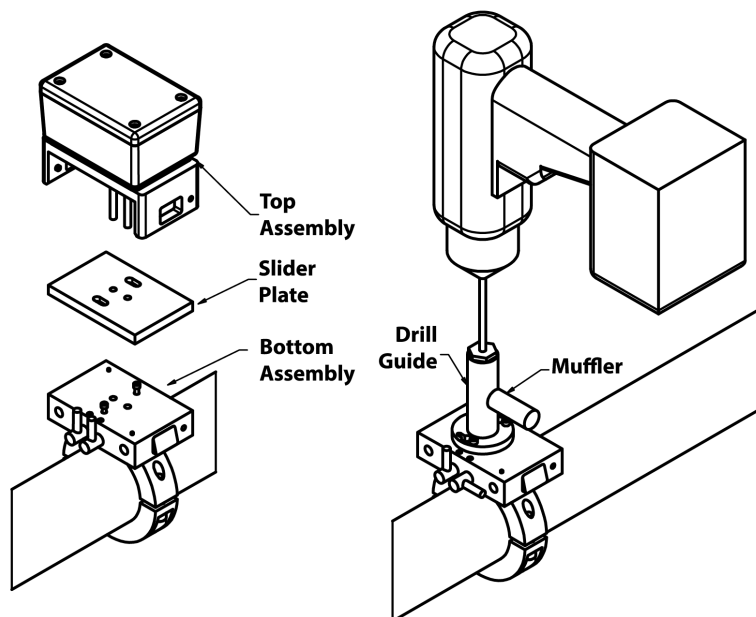

Installation of the Hot Tap Flowmeter should be done by an experienced mechanic. As a precaution, hearing, face, and hand protection should be worn at all times. If done properly, the sound of the drill will be the loudest part of the installation.

The probes of the Hot Tap Digital Flowmeter must be clean before inserting them into the pipe. Remove any oil or dirt using alcohol or a similar degreaser. Tighten the screws carefully, alternating screws so that the two sides of the collars are pulled together evenly. If the yellow caution label is not visible, apply the extra caution label from the bag of parts so it is in a visible location.

Step 1

- A) Mount the base assembly on the pipe and tighten the cap screws evenly. The torque should be sufficient to seal the gasket but not so great that it will crush the gasket, or distort or over-stress the pipe.
- B) Place the drill guide over the exposed socket head cap screws, slide fully to one side and tighten. Orient the drill guide so that the muffler is either horizontal or pointing down.
- C) Open the corresponding valve.
- D) Install the 5/32" drill bit into the drill's chuck. Insert the bit into the drill guide and base until the tip makes contact with the pipe. The distance between the chuck and the top of the drill guide must exceed the thickness of the pipe's wall. Readjust if necessary.

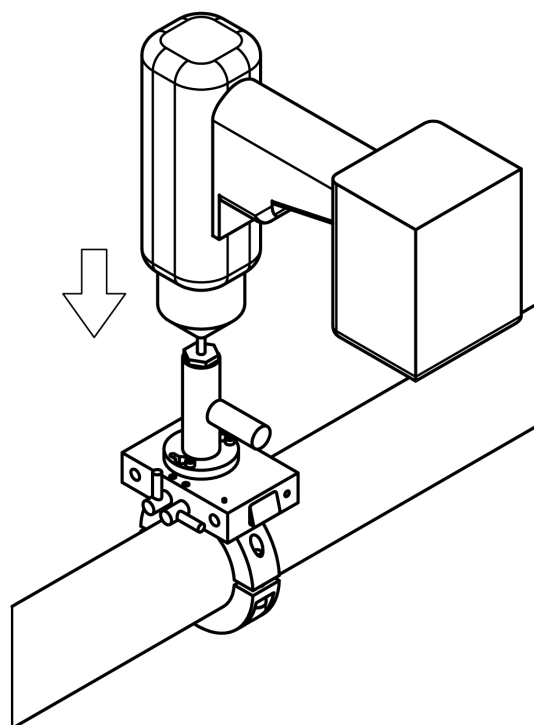

Step 2

- A) Without applying too much force, begin drilling the hole, occasionally backing the drill bit off of the pipe to help clear out chips and dissipate heat.
- B) Once you have broken through the pipe wall, run the drill bit up and down through the hole to ensure clean edges. With the drill bit still spinning, extract it so one to two inches of it is exposed. Be careful not to completely remove the bit or expose the flute. Hold it there for a few seconds to give time for all chips to bypass the drill bit and collect within the muffler.
- C) Carefully remove one hand from the drill and apply light pressure to the corresponding valve handle as if you were closing it. While the bit is spinning, begin extracting the drill bit slowly. The pressure applied to the valve handle will help indicate when the drill bit has cleared. When this happens, rotate the handle 90° to its closed position. It is now safe to completely remove the drill bit. At this stage a slight hiss may be present through the drill guide.
- D) Loosen, but do not remove, the screws holding down the drill guide, slide it so that it aligns with the second hole, and tighten the screws back down.
- E) Open the corresponding valve.
- F) Repeat steps 2A through 2C.

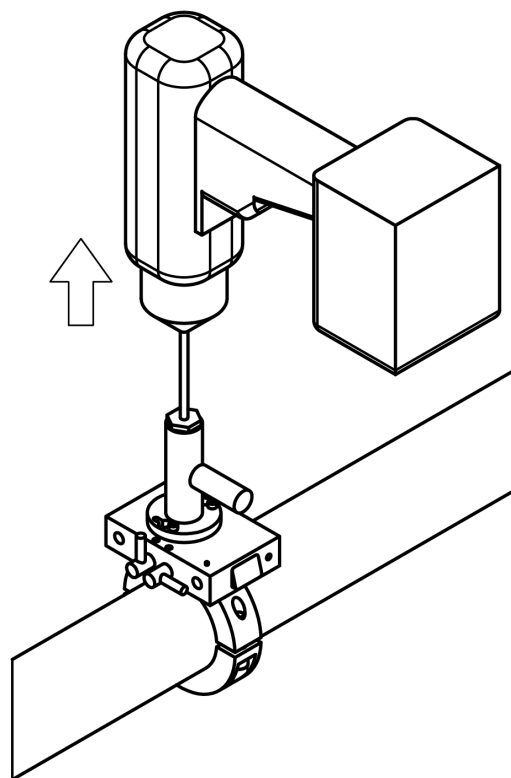

Step 3

- A) Loosen the screws holding down the drill guide, remove it, and empty the chips from the muffler. Wipe away any chips that may have fallen on top of the base. Place the slider plate over the screws with the side containing the O-rings facing the base. Slide it into position so the alignment pins are in place and it sits flat against the base. Tighten the screws so that the slider plate is firmly mounted to the base.
- B) With the flow arrow in the correct direction, insert the probes into the two holes of the slider plate. Expect some resistance as the probes make their way through the O-rings. Continue to push in until the probes make contact with the closed valves. At this point, any leakage noted in step 2C should stop.

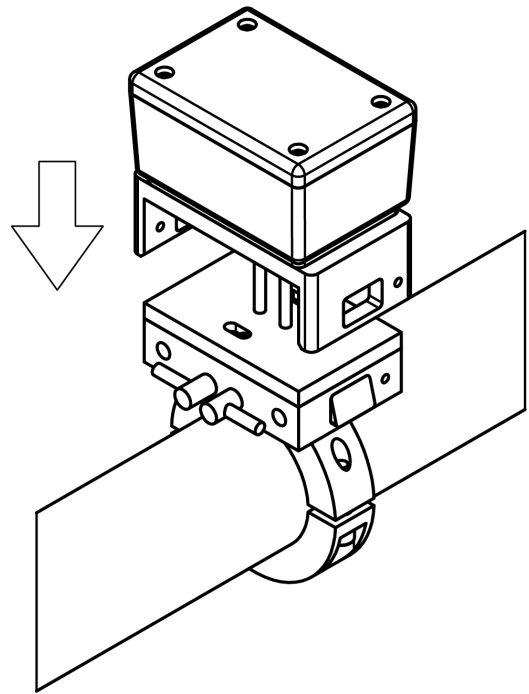

Step 4

- A) With one hand firmly holding the top assembly, use the other to rotate each valve 90° to its open position. Push the top assembly into place until you hear an audible 'click', letting you know the two latches on the sides are now firmly in place and it is safe to let go. You can expect approximately 5 pounds of force at the meter's maximum pressure rating.
- B) To complete installation, there are two safety screws that will need to be placed in the side of the top bracket next to each latch. Screw both in until they bottom out.

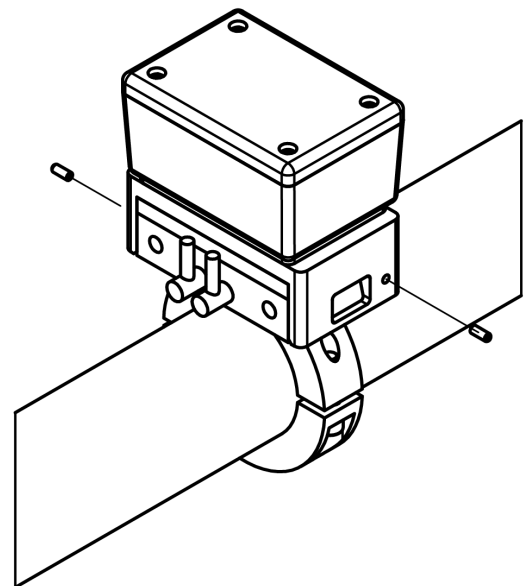

Power Supply

Use the 24 VDC power supply that is provided with the meter. Power Supply requires 100-240VAC. (Note: The 18 volt power supply provided with the previous version will not work with the Rev 3.0 meter.)

Milliamp Output

The mA- and mA+ terminals are optically isolated from the remainder of the circuit and may be wired as part of an externally-powered loop. When this is done, the jumper that is supplied with the meter must be removed. If you use an external power supply, be sure that it has sufficient voltage to overcome an 8.2 volt drop within the meter in addition to any other voltage drops in the loop.

Alternatively, the meter's supply may be used to power the milliamp signal. Leave the jumper in place from the supply+ terminal to mA+. Wire from the mA- terminal to the positive side of the external receiver and from the negative side of the external receiver to the supply terminal. Note that the supply terminal is connected to the aluminum rings, and thus is normally connected to the pipe on which the meter is mounted.

Pulse Output

The pulse output is a transistor switch connected to the meter's negative supply. To use the output, connect it to an input of the receiving device (usually a counter or PLC) and connect a pull-up resistor from that input to a positive supply suitable for the receiving device. Also connect the negative supply terminal of the meter to the negative supply of the receiving device.

Using the Display – Rev 3.0 meters only

The button that controls the display is marked by a circle on the side of the meter. After the power is turned on, pressing the button will cycle through (4) display options: RATE, DAILY USAGE, CUMULATIVE USAGE and UNITS OF MEASURE.

The RATE is rate of air the meter is measuring.

The DAILY USAGE mode displays the usage in thousands of standard cubic feet during the most recent full 24-hour recording period. Holding the button while in this mode will reset the value to zero.

In the CUMULATIVE USAGE mode, the display shows the total air usage in thousands of standard cubic feet. After reaching 9999, it rolls over to 0. It can be used to track monthly air usage and allocate utility costs. The decimal point can be placed to provide better resolution than one thousands of standard cubic feet, but the display will roll over sooner. Holding the button while in this mode will reset the value to zero.

The UNIT OF MEASURE indicates the unit of measure: “0” indicates SCFM, “1” indicates m^3/min and “2” indicates m^3/hr .

Customizing the Display – Rev 3.0 meters only

The button that controls the display is marked by a circle on the side of the meter. Hold the button while the power is off, then apply power to the meter and release the button. The letters “AC” for access code will appear. Press the button repeatedly to cycle to the number 4. After a few seconds, the letters “dd” for default display will appear. Use the button to cycle through the options for the default mode; a “0” indicates rate mode, a “1” indicates daily usage mode, and a “2” indicates cumulative usage mode. Wait, and the letters “dP” for decimal point will appear. Press the button repeatedly to move the decimal point to the desired position for the daily and cumulative usage modes. The letters “du” for display unit will then appear. Cycle through the options for the default units as listed here:

0. Rate in SCFM, daily and cumulative usage in 1000 ft^3 .
1. Rate in m^3/min , daily and cumulative usage in 1000 cubic meters.
2. Rate in m^3/hr , daily and cumulative usage in 1000 cubic meters.

The meter will then return to normal operation.

Using the Outputs

The milliamp output is scaled so that 4 milliamps corresponds to zero flow and 20 milliamps corresponds to a flow rate that is above the calibrated range. There are two ways to determine the flow rate corresponding to 20 milliamps for a particular meter. The first is to look at the sticker inside the meter; it gives both the calibrated full-scale flow and the milliamp range. The second way is to press the button on the main circuit board twice. On the first press, the display will indicate zero and the meter will output four milliamps; and on the second press the display will indicate the full-scale value and the meter will output 20 milliamps. The pulse output generates a square wave signal, sending five pulses for each cubic foot of air that passes through the meter. The LED blinks with the pulse output. At zero flow it may be on or off.

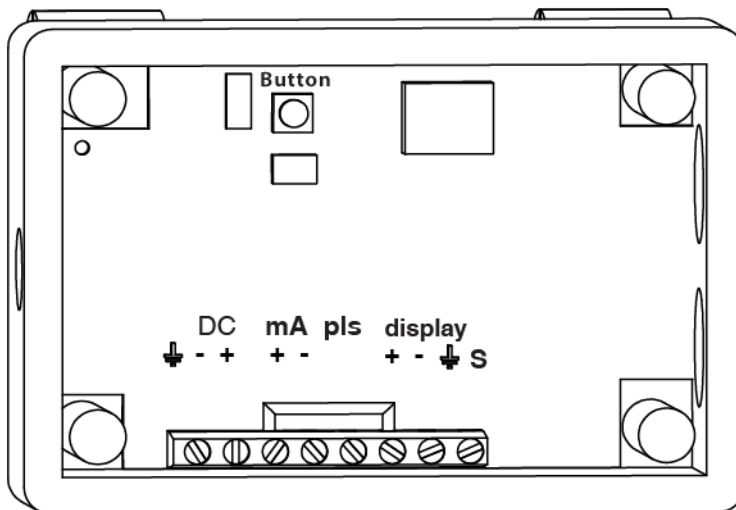

**Shown with top circuit board
Removed for clarity**

Maintenance

If oil or dirt accumulates on the probes, the meter will read low. For this reason, we recommend cleaning the probes from time to time. To clean the probes, wipe them with a cloth dampened with alcohol or a similar degreaser.

If you have any questions or problems, please contact an EXAIR Application Engineer at:

Toll Free: 1-800-903-9247 (US & Canada)
Toll Free Fax: 866-329-3924 (US & Canada)
E-mail: techhelp@exair.com

Telephone: 513 671-3322 outside of US & Canada
Fax: 513 671-3363 outside of US & Canada
Website: www.exair.com